

Wireless Sensor Network Based Patient Health Monitoring and Tracking System

Amitabh Yadav, Vivek Kaundal, Abhishek Sharma, Paawan Sharma,
Deepak Kumar and Pankaj Badoni

Abstract Hospitals need to be equipped with facilities and services to monitor the patients at all times. Due to large number of patients and limited number of doctors, it gets difficult for the doctors to visit each and every patient, and keep track of their improving or deteriorating health condition. This paper presents the structure of an embedded system that could monitor and keep a track of the patients' position and health condition at all times. It makes use of a Wireless Sensor Network of Xbee radios to acquire data, which is then saved in a local database of the central system and simultaneously, also uploaded on an online database to be made available for the doctors to access at all times. The system makes use of active RFID cards to track the position of the patients and along with it the data from the heart beat sensor is transmitted, for each patient separately.

Keywords Arduino · Internet of things · Wireless sensor network · Xbee · Wearable sensors · Wi-Fi

Amitabh Yadav (✉) · Vivek Kaundal · Abhishek Sharma · Paawan Sharma ·
Deepak Kumar · Pankaj Badoni
University of Petroleum and Energy Studies, Dehradun, India
e-mail: amitabhydv@gmail.com

Vivek Kaundal
e-mail: vkaundal@ddn.upes.ac.in

Abhishek Sharma
e-mail: abhishek.sharma@ddn.upes.ac.in

Paawan Sharma
e-mail: paawan.sharma@ddn.upes.ac.in

Deepak Kumar
e-mail: dkumar@ddn.upes.ac.in

Pankaj Badoni
e-mail: pbadoni@ddn.upes.ac.in

© Springer Science+Business Media Singapore 2017
R. Singh and S. Choudhury (eds.), *Proceeding of International Conference on Intelligent Communication, Control and Devices*, Advances in Intelligent Systems and Computing 479, DOI 10.1007/978-981-10-1708-7_106

903

1 Introduction

The advancements in the wearable sensor technology have increased in the recent decades and it is also one of the most thriving areas of research. Often in mental care and healthcare hospitals, patients need to be continuously kept under observation. All their activities need to be kept as a record. For the patients suffering from sleep disorders such as somnambulism (sleepwalking), their movements need to be tracked at all times so that they may not reach any place where they may harm themselves. Similarly, in old age homes and hospitals; there is a need to keep a track of patients' location, monitor their vital signs and maintain it in their records.

Thus, there arises a need for a system to keep a track of movement of the patients, i.e., their location, and at the same time also keep a record of their condition at all times in the form of a database. Such a system also needs to be fully self-sufficient and provides the doctor with the ease of monitoring his patients irrespective of his presence in the hospital; thus, the data must be accessible from any place and at all times.

For acquiring data from multiple sources (nodes) and arranging it together in a central system, it requires setting up of a wireless sensor network (WSN). The data is acquired on a central system, along with the information about the source of origin of each data and saved in an optimized way. Thus, a WSN can be created in a large-scale healthcare center to optimize and automate the task of patient tracking and health monitoring. The data can be made available to the doctor by connecting the overall system to the internet and sending the acquired data to be saved in an online database, the access to which can be provided by simply logging into the user account.

Such a system finds application in many domains of health monitoring, such as in hospitals, tracking and health monitoring at home for infants and elderly, sports training, military, etc.

2 Related Works

The research in the area of wearable sensor technology has been booming in the past few years, employing various biomedical sensors; and it has also proved to gain a lot of scientific attention. The outlook provided by researchers and clinic officials of the recent advancements made in the field of wearable technology has intrigued the ideas of the possibility offered by gathering data from sensors [1, 2]. Wearable computing has originated from placing sensors on the body and interfacing them wirelessly to create a body area network (BAN) that can sense and report the user's attributes [3, 4]. A variety of system's shortcomings have been addressed in biomedical wearable sensor technology, regarding reliability, privacy issues, user interface, etc., and still the continuous development in wearable sensor

based system will advance and be a transforming motivation for the future of healthcare [5, 6, 7].

Previously, systems were integrated with vital sign sensors and location sensors to create ad hoc network and gather patient data for applications at disaster struck areas [8]. The monitoring of the posture and activities can be performed using shoe-based wearable sensors that enable monitoring of energy exhausted, thus, proving to be an aid in checking obesity [9]. Intelligent health monitors that are portable can also be employed, like ECG and ischemia [10]. Researchers have focused to develop on the design of sensors so that they are minimally obtrusive and record the physiological signals. The work to develop algorithms for extracting required information from wearable technology is a flourishing area of research [11]. Employing wearable sensors that are permanently implanted, along with wearable monitoring, has the ability to provide continuous data of critical physiological terms for pre-identifying major adverse conditions in health. UbiMon Body Sensor network is also developed and investigated for activity recognition and health monitoring [12].

The developments in the sensor network technology have been brought about by the putting together the electro-mechanical systems at miniature level, wireless communication technology and digital electronics [13]. Recent developments in the analysis of signal processing of the time-domain signals have shown improvement in measurement of SpO₂ [14]. The miniaturization, the prolonged time of operation of medical sensors and integrating them with medical systems have enabled the patients to get a real-time data of their health condition [15]. The concept of using multiple layer distributed network for data acquisition has been implemented in biomedical systems [16, 17]. WSN of a large number of sensor nodes with the capability of multi-hop networking can be implemented to record sensor data, such as temperature [18], habitat monitoring [19]; and can also be used easily for monitoring in military, sports and biomedical applications [20]. There are many options to do this, such as by using Bluetooth, Xbee protocol and Wi-Fi systems, etc. [21].

However, lack of reliable communication and a limited bandwidth create challenges for implementing a sensor network. Studies to determine the performance of Xbee based WSN have been conducted in indoor environment, and extended study for enhancing the performance needs to be conducted [22]. But, low-power wireless sensor networks hide within it the potential to impact tremendously in the field of healthcare [23]. Systems have been developed using the mobile or PDA systems to provide health data acquired from wearable sensors, by making use of wireless telecommunications technology and the communication devices [24] and synchronizing the records that are collected with records that previously exist on the centralized server [25] or by comparatively easier way of creating a MATLAB based graphical user interface (GUI) [26, 27] or Microsoft Visual Studio based computer interfacing [28]. Techniques to gather data by creating a personal area network (PAN) of the employed sensors are used. However, it proves not very useful for data acquisition for a longer duration [29]. A GSM and Internet of Things (IoT) based system is employed that functions by sending messages and email for

real-time monitoring [30]. Another method is by using Bluetooth enabled wearable sensor, which is suitable for health monitoring at home [31].

Tracking of personal in a building can be done using various techniques ranging from RF-based systems [32], LANDMARC system employing radio frequency identification (RFID) [33, 34], active RFID based indoor localization [35], active badges for tracking in the office environment [36], GPS tracking, etc. The approach to indoor localization of the person has been studied in detail previously using active RFIDs; and enhanced approach to achieve higher accuracy than LANDMARC system has also been studied [37, 33, 35].

WSN, the IoT and machine to machine (M2M) interaction are some of the topics that have developed in the recent years and there is a need for module based, low-cost and easy-to-use platforms to creating network systems for developing software applications of WSN, IoT and other related technologies [38].

3 Proposed System

The idea behind the development of such a system is to automate the process of examining patients. Continuous monitoring of each patient is the most important aspect of designing the system. The system must be able to correctly identify each patient, and must be able to correctly match the data with the corresponding patient's details. In this section, we will elaborate on the subsystems and the block diagram of operation.

The overall system comprises of the following subsystems:

a. Patient Module

The patient module is a wearable device for the patients, comprising of (1) an active RFID card, which transmits a unique address for each patient; (2) a heartbeat (HB) sensor to read information of their vital signs and blood pressure levels; (3) an RF module, to transmit the readings to the data receiver unit; and (4) a microcontroller (Arduino), to acquire data from the HB-sensor via the ADC port and transmit using the RF module via the UART protocol. These patient modules act as end points in the proposed wireless sensor network (WSN). They are provided to each patient, who is then identified by their unique RFID addresses. The data is transmitted to the data receiver unit, which act as Routers to our gathered data, and route the collected data to the central system module clubbed with the unique RFID address of the patients.

b. Data Receiver Unit

The data receiver modules are systems that are installed in each room/corridor of a healthcare center. It comprises of (1) an RF Receiver, to receive data from the patient modules (end points); (2) an active RFID reader module, which continuously scans the area within 25 m range for presence of any patient, identified by their unique RFID address; (3) an Xbee S2 module, to resend the final data packets to the central system module, (4) an SD-Card module, which has the

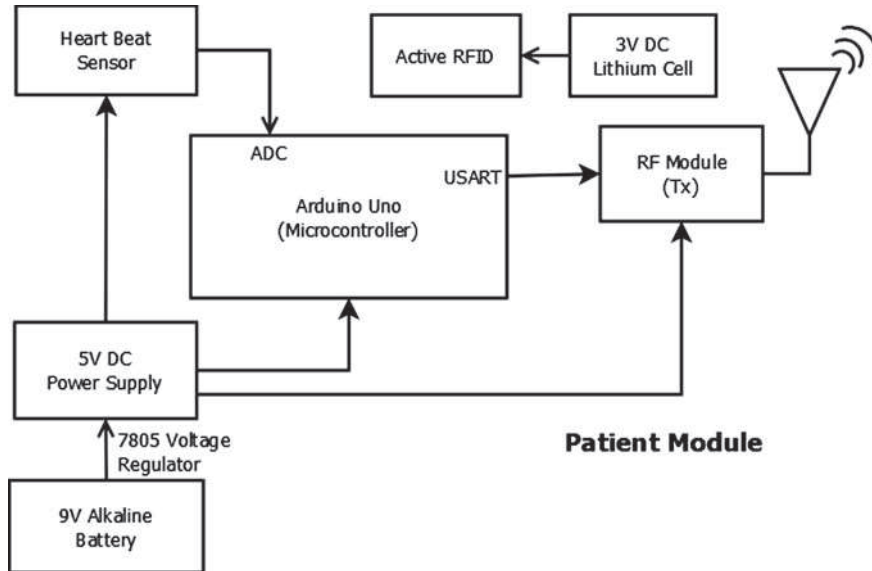

Fig. 1 Block diagram—patient module

information of each patient stored with their corresponding RFID address; and (5) microcontroller (Arduino) that acts as the interface for all the connected modules and runs the program for data receiving, patient identification and re-transmitting (Figs. 1, 2, 3, 4, 5 and 6).

c. Central System Module

The central system module is the center of the WSN. It is the central system, where all the data is received and tabulated in a local database on the PC. It is also responsible for uploading the acquired data on the internet to be made accessible to the doctors at all times. It comprises of (1) an Xbee S2 receiver module, i.e., the coordinator Xbee, placed in the form of star topology, which receives the data from all the data receivers in the healthcare center; (2) a Wi-Fi module that acts as the interface for uploading the data on the internet via the 802.11 b/g/n Wi-Fi protocol; and (3) microcontroller (Arduino), which acts as the interface for the PC, Xbee, Wi-Fi module and runs the code to identify the location of the transmitters in the network, and using this information, identifies the location of the patients in the healthcare center.

3.1 Hardware Development

The hardware development of the system can be divided for the comprising three subsystems—the patient module, the data receiver unit and the central system.

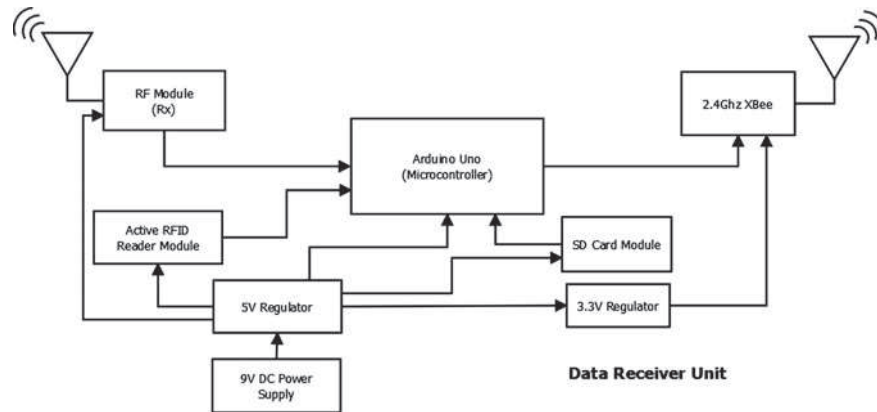

Fig. 2 Block diagram—data receiver unit

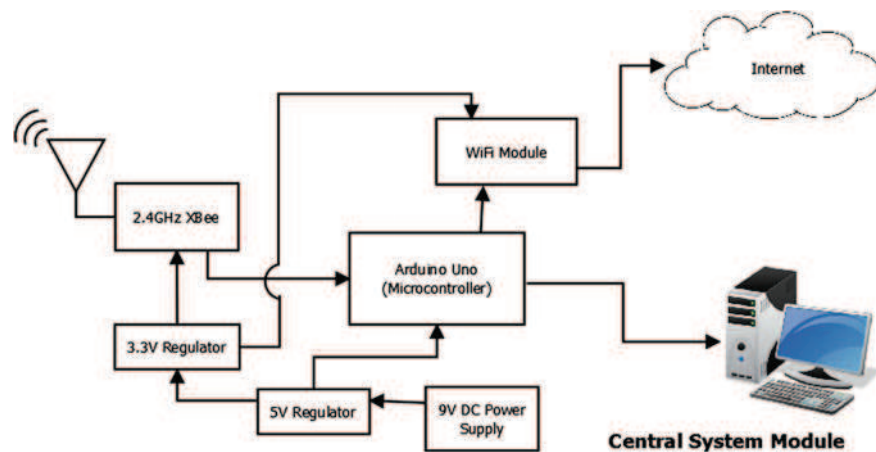

Fig. 3 Block diagram—central system module

Patient Module. The main components of the Patient module are:

- Active RFID Transmitter: Powered by a 3 V mounted battery and transmits a 16-bit unique code every 6 s on 433 MHz frequency in a range of 25 m.
- Pulse Sensor: It is a well-designed heart-rate sensor. Operates on +3 to +5 V, consumes 4 mA of current and provides analog output.
- Arduino Uno: It is the microcontroller board that is employed. It is based on ATmega328P, has 14 digital input/output pins (6 PWM outputs) and 6 analog inputs. A +5 V regulated DC current from a 9 V alkaline battery is used to power the components
- RF Serial Data Link UART, 2.4 GHz: It is a data modem operating in half duplex communication mode. It transmits serial data at baud rate 9600 bps.

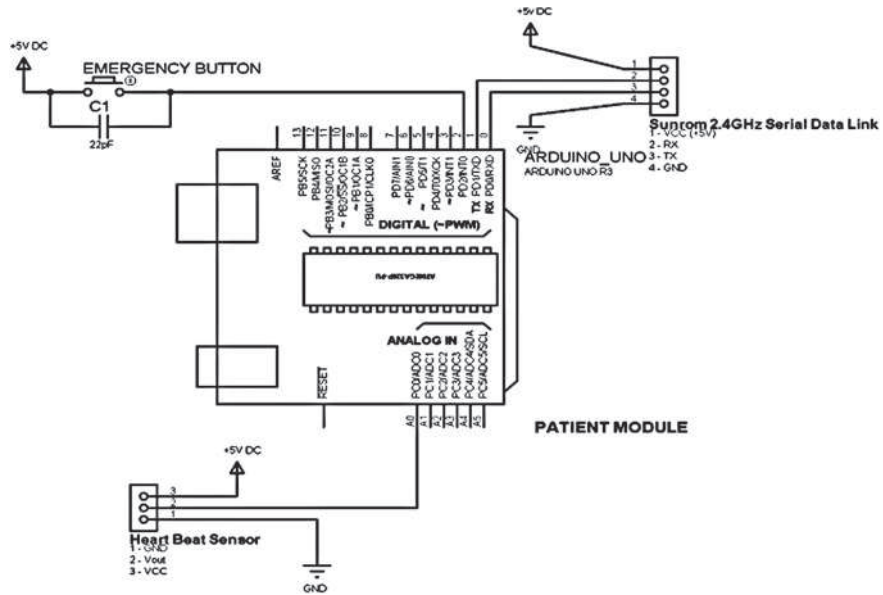

Fig. 4 Circuit diagram—patient module

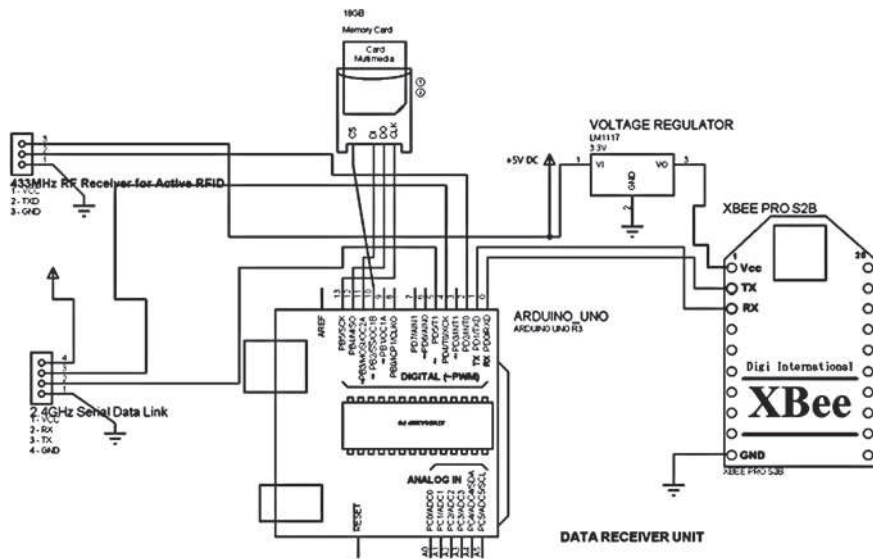

Fig. 5 Circuit diagram—data receiver unit

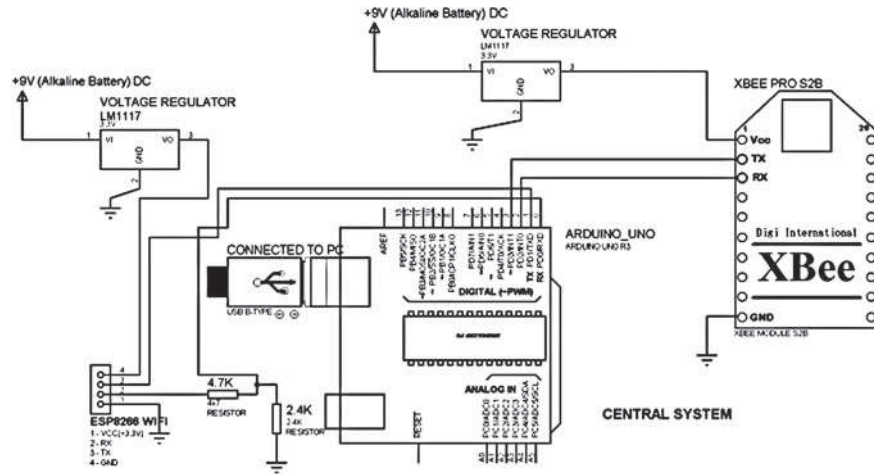

Fig. 6 Circuit diagram—central system

Data Receiver Unit. The main components of the data receiver unit are as follows:

- RF Receiver for Active RFID: It receives on 433 MHz frequency for active RFID and outputs the unique 16 bit ID in serial ASCII format at 9600 bps baud rate. RF Serial Data Link UART, 2.4 GHz: It receives serial data at baud rate 9600 bps.
- Micro SD Breakout Board: Used to store the details of the active RFIDs with corresponding allotted values (See Sect. 3.5 for details.)
- 2.4 GHz Xbee Pro S2B: These are used to re-transmit the data to the central system and allow a very reliable and simple communication. It operates on 3.3 V@ 295 mA, with 250 kbps Max data rate, 63 mW output (+17 dBm) and gives 1500 m indoor range.
- Arduino Uno: It is the microcontroller board that is employed. It receives data from the RF Serial Data Link and RF Receiver for active RFID, binds in a string and retransmits to the central system via the Xbee radio. A +5 V regulated DC current from a 9 V alkaline battery is used to power the components. A separate +9 V Alkaline battery is used to meet the power requirements (+3.3 V/63 mW) of the Xbee Pro S2B.

Central System Module. The main components of the central system module are as follows:

- 2.4 GHz Xbee Pro S2B: It is used as the receiver at the central system module.
- Arduino Uno: It is the microcontroller board that is employed. It runs the code for receiving data from the Xbee on various nodes (Xbee on the Data Receiver Unit), sending it to the PC and simultaneously uploading it on the internet database.

- ESP8266 ESP-12 Wi-Fi Module: It is a self-contained System-On-Chip (SOC) with integrated TCP/IP protocol stack that gives the microcontroller, access to a Wi-Fi network.
- Power Supply: The microcontroller is powered from the PC itself via the USB connection. The Xbee Pro S2B and ESP8266 Wi-Fi are powered with +3.3 V DC by regulating the voltage from a 9 V Alkaline Battery using an LM1117 IC.
- PC: PC or personal computer is the system which is used as an interface to gather the acquired data. The system uses a GUI built in MATLAB environment, which continuously displays the data for each patient, saves in a database (a comma-separated-value (CSV) file).

3.2 Algorithm and Software Development

The proposed algorithm for various subsystems is implemented in Arduino IDE software. In this section, the flow of operations using a methodical approach using a flowchart is explained.

3.3 Patient Module

The Arduino Uno on the patient module is concerned with the acquisition of data from the health sensors (pulse sensor) and transmitting to the data receiver unit. It makes use of the analog input pin for reading the data from the pulse sensor and transmits the data on the serial link set at a baud rate of 9600 bps using the 2.4 GHz RF Serial Data Link UART module, which can be regarded as the end node of the sensor network. The flowchart for the same is demonstrated in Fig. 7.

The patient module also consists of an active RFID Transmitter Tag which is an independent module i.e. it has not been interfaced with the Arduino and does not require programming. It transmits a unique 16-bit ID every 6 s, to the receiver at the Data Receiver Unit.

3.4 Data Receiver Module

The data receiver unit has multiple serial devices—RF receiver for active RFID, RF Serial Data Link 2.4 GHz and Xbee Pro S2B—connected to the Arduino Uno. Since, Arduino Uno has only one serial communication port (digital pins 0 and 1), it requires to make two extra serial ports using the ‘SoftwareSerial’ library. Second, a Micro SD card is used with the data receiver unit to store the addresses of all the

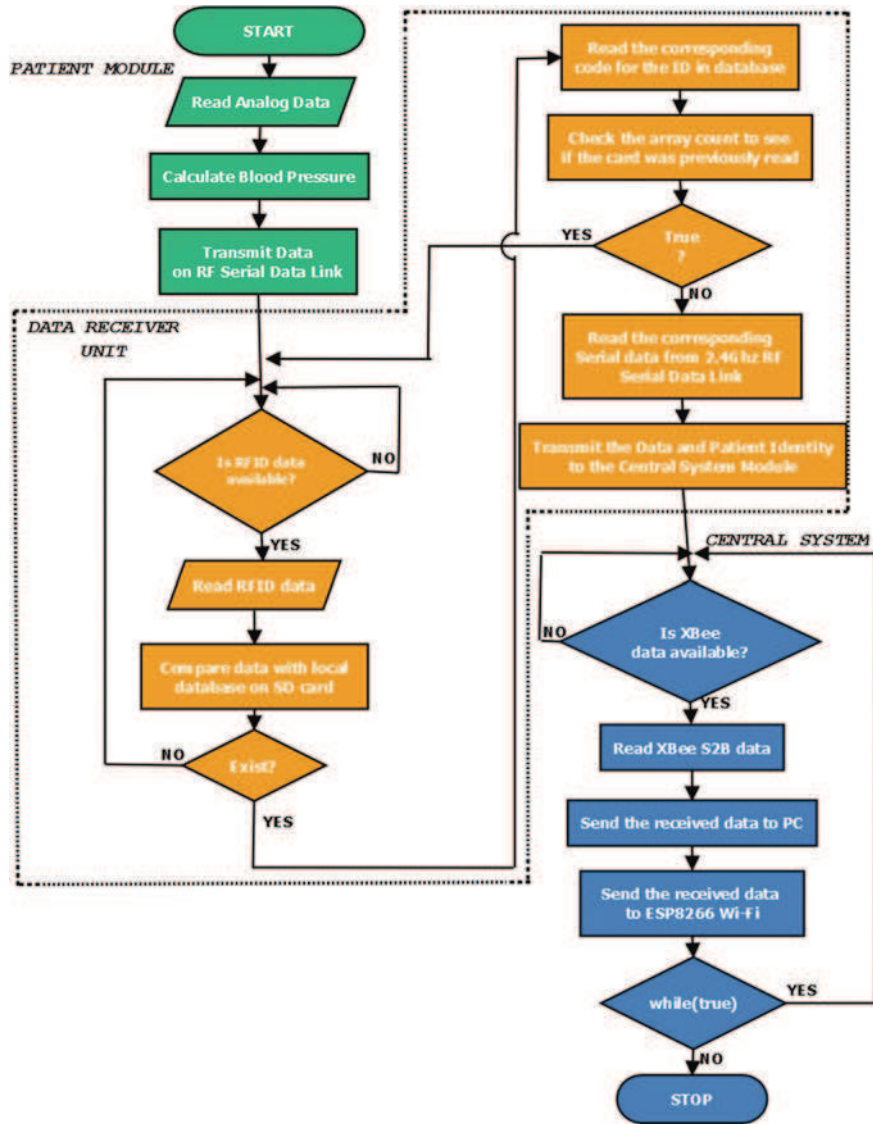

Fig. 7 Flowchart for the algorithm of overall system

Active RFID Transmitter Tag, and then used to identify the patients’ identity, through the algorithm. The flowchart for the same is demonstrated in Fig. 7.

3.5 Central System Module

The Xbee Pro S2B at the central system acts as the Coordinator Xbee in the WSN and receives the data from all the Router Xbee Pro S2B placed in various wards/corridors/rooms in the healthcare center. It receives the data from all the Router Xbee and also identifies the source of origin of the data. The data along with the source information is wrapped as a string and sent to the PC. Simultaneously, it is also uploaded to the internet via ESP8266 Wi-Fi module in the optimized format. The flowchart for the algorithm for central system is demonstrated in Fig. 7.

3.6 Graphical User Interface (GUI) Development

A GUI developed in MATLAB is used as a Serial terminal. It makes use of push button option to open/close COM port and receive data. The string of data which is received contains the source of origin, patient's identity information and the pulse sensor reading. The GUI (developed in MATLAB) runs the algorithm which separates the relevant information from the received string, and displays it to the user in an optimized and precise format. Simultaneously, it also saves the received data in a CSV file on the local system.

4 Results and Discussions

The proposed system has been designed, evaluated and data acquired. It was realized on a small scale using two patient modules, two data receiver units and one central system module. In this paper, we have presented the findings based on the overall system performance, power consumption and error in the readings.

The data received from the pulse sensor was accurate, and provided substantial information about health from the obtained beats-per-minute (bpm) readings. The waveform of the readings is as shown in the Fig. 8d.

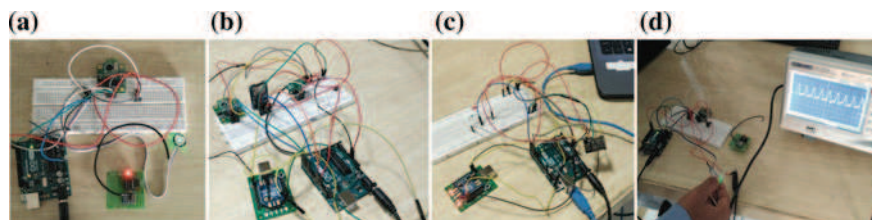

Fig. 8 Experimental Setup—**a** Patient module. **b** Data receiver unit. **c** Central system. **d** Data transmission testing and heart beat readings (each crest on waveform represents a heartbeat)

The active RFID cards transmit the associated ID every 6 s and each RFID was uniquely identified. Errors were identified to have occurred at the receiver, when more than 1 reading was obtained. So the problem was diagnosed by bypassing the extra reading in the algorithm on the data receiver unit. According to the datasheet, a total of 64 active RFID transmitter tags can exist together in same region, with each automatically occupying its own time slot without interfering with another. Thus, it limits the maximum number of patients that can be detected in a room to 64.

The 2.4 GHz Serial Data Link is used as transmitter and receiver at the end nodes of the sensor network, which perform well when a limited number of patients are present in the room. However, when dealing with large number of patients, it causes the problem of interference. Thus, readings are not obtained precisely. However, a solution to this problem has been identified to use 2.4 GHz Xbee Radio. It offers less interference compared to 2.4 GHz Serial Data Link, and can be ideally used for dealing with large number of patients. The disadvantage with using an Xbee radio is that, it highly increases the cost of the system.

The ESP8266 was used to connect to the internet via an open Wi-Fi network, which sends the readings to *thingspeak.com*, which is an online data platform for Internet of Things. The acquired readings are saved online without error. These readings can be accessed by any authorized personal (doctors) by logging into the online account using the correct credentials.

5 Conclusion and Future Work

The proposed system is intended to help the hospitals in better treatment of its patients and also to make it convenient for the doctor to check up his patients. The system can further be improved in many terms, some of which are stated as follows:

- i. It is a simplified and cheap version of an advanced patient monitoring system. Using apt wireless technology, the system could be further developed to spread and work over several hospitals, i.e., in a wide range, using a free wireless network. Also, the system can be extendedly be used for home monitoring of the patients.
- ii. More number of health issues can be investigated, as per requirement using adequate sensors. For example, muscle activity can be measured by its electric potential, referred to as electromyography (EMG), using a Muscle Sensor; the ECG sensor module AD8232 can be used to measure electrical activity of heart by attaching ECG electrodes to the patient's body etc.
- iii. The GUI can be further upgraded to let the doctors have the ease to make specific appointments with a particular patient, set reminder for attending a patient, keep a proper database and remarks for every patient. Further, data-base encryption can also be implemented to restore the privacy rights of the patients.

References

1. Bonato, P., R. Hughes, D. Sherrill, R. Black-Schaffer, M. Akay, B. Knorr, and J. Stein. "Using wearable sensors to assess quality of movement after stroke." *Proceedings of the 65th Annual Assembly American Academy of Physical Medicine and Rehabilitation 2004* (2004).
2. Park, Sungmee, and Sundaresan Jayaraman. "Enhancing the quality of life through wearable technology." *Engineering in Medicine and Biology Magazine, IEEE* 22, no. 3 (2003): 41–48.
3. Jurik, Andrew D., and Alfred C. Weaver. "Remote medical monitoring." *Computer* 41, no. 4 (2008): 96–99.
4. Jovanov, Emil, Amanda O'Donnell Lords, Dejan Raskovic, Paul G. Cox, Reza Adhami, and Frank Andrasik. "Stress monitoring using a distributed wireless intelligent sensor system." *Engineering in Medicine and Biology Magazine, IEEE* 22, no. 3 (2003): 49–55.
5. Pantelopoulos, Alexandros, and Nikolaos G. Bourbakis. "A survey on wearable sensor-based systems for health monitoring and prognosis." *Systems, Man, and Cybernetics, Part C: Applications and Reviews, IEEE Transactions on* 40, no. 1 (2010): 1–12.
6. Shih, E., V. Bychkovsky, D. Curtis, and J. Guttag. "Demo abstract: Continuous, remote medical monitoring." In *Proc. Second Annual International Conference on Embedded Networked Sensor Systems*. 2004.
7. Martin, Thomas, Emil Jovanov, and Dejan Raskovic. "Issues in wearable computing for medical monitoring applications: a case study of a wearable ECG monitoring device." In *Wearable Computers, The Fourth International Symposium on*, pp. 43–49. IEEE, 2000.
8. Gao, Tia, Dan Greenspan, Matt Welsh, Radford R. Juang, and Alex Alm. "Vital signs monitoring and patient tracking over a wireless network." In *Engineering in Medicine and Biology Society, 2005. IEEE-EMBS 2005. 27th Annual International Conference of the*, pp. 102–105. IEEE, 2006.
9. Sazonov, Edward S., George Fulk, James Hill, Yves Schütz, and Raymond Browning. "Monitoring of posture allocations and activities by a shoe-based wearable sensor." *Biomedical Engineering, IEEE Transactions on* 58, no. 4 (2011): 983–990.
10. Jovanov, Emil, Pedro Gelabert, Bryan Wheelock, Reza Adhami, and Paul Smith. "Real time portable heart monitoring using low power dsp." In *International Conference on Signal Processing Applications and Technology ICSPAT*, pp. 16–19. 2000.
11. Bonato, Paolo. "Advances in wearable technology and applications in physical medicine and rehabilitation." *Journal of NeuroEngineering and Rehabilitation* 2, no. 1 (2005): 2.
12. Van Laerhoven, Kristof, Benny PL Lo, Jason WP Ng, Surapa Thiemjarus, Rachel King, Simon Kwan, Hans-Werner Gellersen et al. "Medical healthcare monitoring with wearable and implantable sensors." In *Proc. of the 3rd International Workshop on Ubiquitous Computing for Healthcare Applications*. 2004.
13. Akyildiz, Ian F., Weilian Su, Yogesh Sankarasubramaniam, and Erdal Cayirci. "Wireless sensor networks: a survey." *Computer networks* 38, no. 4 (2002): 393–422.
14. Rusch, T.L., R. Sankar, and J.E. Scharf. "Signal processing methods for pulse oximetry." *Computers in biology and medicine* 26, no. 2 (1996): 143–159.
15. Raskovic, Dejan, Thomas Martin, and Emil Jovanov. "Medical monitoring applications for wearable computing." *The Computer Journal* 47, no. 4 (2004): 495–504.
16. Bauer, Peter, Mihail Sichitiu, Robert Istepanian, and Kamal Premaratne. "The mobile patient: wireless distributed sensor networks for patient monitoring and care." In *Information Technology Applications in Biomedicine, 2000. Proceedings. 2000 IEEE EMBS International Conference on*, pp. 17–21. IEEE, 2000.
17. Barro, S., J. Presedo, D. Castro, M. Fernandez-Delgado, S. Fraga, M. Lama, and J. Vila. "Intelligent telemonitoring of critical-care patients." *Engineering in Medicine and Biology Magazine, IEEE* 18, no. 4 (1999): 80–88.

18. Boonsawat, Vongsagon, Jurarat Ekchamanonta, Kulwadee Bumrunghet, and Somsak Kittipiyakul. "XBee wireless sensor networks for temperature monitoring." In *the second conference on application research and development (ECTI-CARD 2010), Chon Buri, Thailand*. 2010.
19. Szewczyk, Robert, Alan Mainwaring, Joseph Polastre, John Anderson, and David Culler. "An analysis of a large scale habitat monitoring application." In *Proceedings of the 2nd international conference on Embedded networked sensor systems*, pp. 214–226. ACM, 2004.
20. Rashid, Rozeha, Sharifah Hafizah Syed Arifin, Mohd Rozaini Abd Rahim, Mohd Adib Sarijari, and Nur Hija Mahalin. "Home healthcare via wireless biomedical sensor network." In *RF and Microwave Conference, 2008. RFM 2008. IEEE International*, pp. 511–514. IEEE, 2008.
21. Nugroho, Eko, and Alvin Sahroni. "ZigBee and wifi network interface on Wireless Sensor Networks." In *Electrical Engineering and Informatics (MICEEI), 2014 Makassar International Conference on*, pp. 54–58. IEEE, 2014.
22. Ibrahim, Ahmad Shahrar, Zairi Ismael Rizman, and Nur Hafizah Rabi'ah Husin. "Performance Analysis of Xbee-Based WSN in Various Indoor Environments." *J. Basic Appl. Sci. Res* 3, no. 11 (2013): 20–27.
23. Shnayder, Victor, Bor-rong Chen, Konrad Lorincz, Thaddeus RF Fulford Jones, and Matt Welsh. "Sensor networks for medical care." In *SenSys*, vol. 5, p. 314. 2005.
24. Kroc, S., and Vlado Delic. "Personal wireless sensor network for mobile health care monitoring." In *Telecommunications in Modern Satellite, Cable and Broadcasting Service, 2003. TELSIKS 2003. 6th International Conference on*, vol. 2, pp. 471–474. IEEE, 2003.
25. Jovanov, Emil, Amanda O. Donnel, Andy Morgan, Brent Priddy, and Rick Hormigo. "Prolonged telemetric monitoring of heart rate variability using wireless intelligent sensors and a mobile gateway." In *Engineering in Medicine and Biology, 2002. 24th Annual Conference and the Annual Fall Meeting of the Biomedical Engineering Society EMBS/BMES Conference, 2002. Proceedings of the Second Joint*, vol. 3, pp. 1875–1876. IEEE, 2002.
26. Gupta, R., J.N. Bera, and M. Mitra. "Development of an embedded system and MATLAB-based GUI for online acquisition and analysis of ECG signal." *Measurement* 43, no. 9 (2010): 1119–1126.
27. Schultz, Robert C., and Robert W. Ives. "Biometric data acquisition using MATLAB GUIs." In *Frontiers in Education, 2005. FIE'05. Proceedings 35th Annual Conference*, pp. S1G-1. IEEE, 2005.
28. Ling, Tonny Heng Yew, Lim Jin Wong, Jocelyn Ee Hung Tan, and Chong Kee Lee. "XBee Wireless Blood Pressure Monitoring System with Microsoft Visual Studio Computer Interfacing." In *Intelligent Systems, Modelling and Simulation (ISMS), 2015 6th International Conference on*, pp. 5–9. IEEE, 2015.
29. Jovanov, Emil, Dejan Raskovic, John Price, A. Krishnamurthy, J. Chapman, and A. Moore. "Patient monitoring using personal area networks of wireless intelligent sensors." *Biomedical Sciences Instrumentation* 37 (2001): 373–378.
30. Prakash, R., Siva V. Girish, and A. Balaji Ganesh. "Real-Time Remote Monitoring of Human Vital Signs Using IoT and GSM Connectivity." In *Proceedings of the International Conference on Soft Computing Systems*, pp. 47–56. Springer India, 2016.
31. Barnes, G. Edward, and Steve Warren. "A wearable, Bluetooth-enabled system for home health care." In *Engineering in Medicine and Biology, 2002. 24th Annual Conference and the Annual Fall Meeting of the Biomedical Engineering Society EMBS/BMES Conference, 2002. Proceedings of the Second Joint*, vol. 3, pp. 1879–1880. IEEE, 2002.
32. Bahl, Paramvir, and Venkata N. Padmanabhan. "RADAR: An in-building RF-based user location and tracking system." In *INFOCOM 2000. Nineteenth Annual Joint Conference of the IEEE Computer and Communications Societies. Proceedings. IEEE*, vol. 2, pp. 775–784. IEEE, 2000.
33. Ni, Lionel M., Yunhao Liu, Yiu Cho Lau, and Abhishek P. Patil. "LANDMARC: indoor location sensing using active RFID." *Wireless networks* 10, no. 6 (2004): 701–710.

34. Weinstein, Ron. "RFID: a technical overview and its application to the enterprise." *IT professional* 7, no. 3 (2005): 27–33.
35. Jin, Guang-yao, Xiao-yi Lu, and Myong-Soon Park. "An indoor localization mechanism using active RFID tag." In *Sensor Networks, Ubiquitous, and Trustworthy Computing, 2006. IEEE International Conference on*, vol. 1, 4 pp. IEEE, 2006.
36. Want, Roy, Andy Hopper, Veronica Falcao, and Jonathan Gibbons. "The active badge location system." *ACM Transactions on Information Systems (TOIS)* 10, no. 1 (1992): 91–102.
37. Jiang, Xuejing, Ye Liu, and Xiaolei Wang. "An enhanced approach of indoor location sensing using active RFID." In *Information Engineering, 2009. ICIE'09. WASE International Conference on*, vol. 1, pp. 169–172. IEEE, 2009.
38. Dobrilovic, Dalibor, Zeljko Stojanov, and Borislav Odadzic. "Teaching application development for RFID/ZigBee networks using open source hardware." In *Telecommunications (BIHTEL), 2014 X International Symposium on*, pp. 1–6. IEEE, 2014.